

REAR – AIR SPRING ASSEMBLY

Removal



WARNING: The air suspension system is under pressure (up to 10 bar, or 150 lbf/in²). Do not allow dirt or grease to enter the system. Always wear standard protective hand, ear, and eye protection when servicing the air suspension system.



WARNING: Do not inflate the air spring assembly unless it is supported on both ends by the vehicle frame and suspension system. An unrestricted or unsupported air spring could cause serious injury and damage to the air spring assembly. **DO NOT DISASSEMBLE THE AIR SPRING!**

1. Raise the vehicle on a hoist or other adequate structure. **WARNING:** Always support the vehicle on safety stands. Refer to your vehicle's Owner's Manual for correct lifting instructions.
2. Remove the rear wheel arch liner.
3. Support the chassis from under the rear cross member. **Depressurize the air suspension system.**
4. With pliers, or a suitable hooked tool, remove the clip that secures the top of the air spring to the chassis. **NOTE: To access the clip, go under the wheel arch, between the body of the vehicle and the chassis.**
5. After removing the clip, affix the bottom of the air spring to axle.
6. Raise chassis for extra clearance for removing the old spring. Re-support the chassis.
7. Remove the air spring from chassis. Clean connections and disconnect the air hose.
8. Seal off hose to prevent dirt or grease from entering system.



CAUTION: When refitting the new air spring, do not allow the vehicle to rest on the deflated air spring. The chassis must be supported until the new air spring is inflated.

Refitting

9. Refit new rear air spring; remove seal from air hose. Connect the hose to the air spring.
10. Affix the air spring to the chassis. Secure the top of the air spring to the chassis with the removed clip.



CAUTION: Ensure the air hose is routed correctly and that it is free of kinks or bends.

11. Remove the support from the chassis and slowly lower air spring onto the axle. Re-support the chassis.
12. Fit the clip to secure bottom of the air spring to axle.
13. Remove all safety stands and lower vehicle.
14. Re-inflate system and perform a leak test on the air spring and connector with a soapy water solution.



WARNING: Make sure to tighten all wheel hub bolt nuts to 115-142 Nm (85-105 lb/ft).

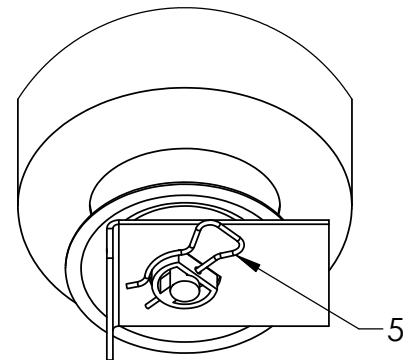
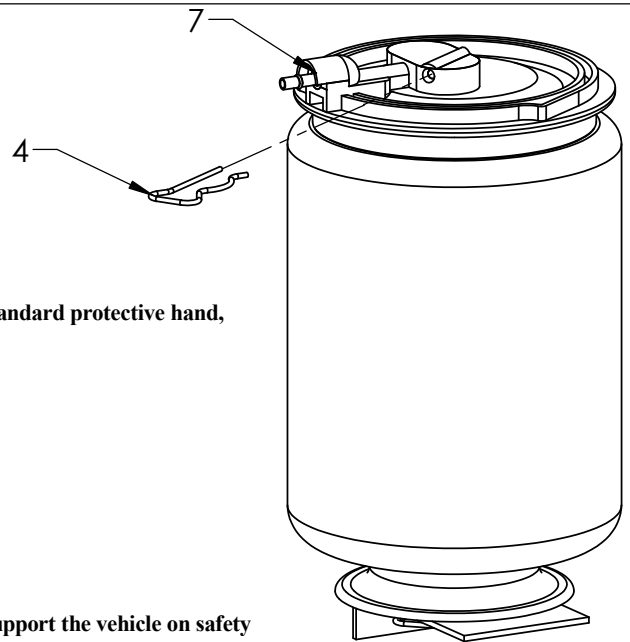

			DIMENSIONS ARE IN INCHES TOLERANCES: FRACTIONAL ± ANGULAR: MACH ± BEND ± TWO PLACE DECIMAL ± THREE PLACE DECIMAL ±	NAME	DATE	<h1>RANGE ROVER REAR AIR SPRING</h1>	
				DRAWN	RLS		05/30/06
				CHECKED			
				ENG APPR.			
			MFG APPR.				
			Q.A.				
			COMMENTS:				
<p>PROPRIETARY AND CONFIDENTIAL THE INFORMATION CONTAINED IN THIS DRAWING IS THE SOLE PROPERTY OF ARNOTT, INC. ANY REPRODUCTION IN PART OR AS A WHOLE WITHOUT THE WRITTEN PERMISSION OF ARNOTT, INC. IS PROHIBITED.</p>	NEXT ASSY	USED ON	FINISH			SIZE A	
	APPLICATION		DO NOT SCALE DRAWING			DWG_NO. REAR ILLUSTRATION-A	
					SCALE: 1:4	WEIGHT:	REV. 0
						SHEET 1 OF 1	